

AMIT 3.0

The unattended industry's
remote secure terminal

Taking the guesswork out of **management & restocking**

A complete M2M telemetry solution
ideally suited for unattended
machine operators and other
unattended applications

Remote Secure Terminal

- ▶ External communication -
GSM/GPRS/CDMA/Ethernet/Wifi
- ▶ MDB/Pulse/VCCS/ccTalk
- ▶ DEX/DDCMP/RS232 Interface



1

Intelligent Telemetry

The AMIT 3.0 from Nayax is an intelligent telemetry device that provides the ability to monitor machines in real-time with continuously updated information on all aspects of operation.

2

Enabling Powerful Capabilities

Inventory, cash monitoring, alerts, reports, route planning and remote device control

NAYAX
Attending to the Unattended

Executive Plaza 1, 11350 McCormick Road, Suite 1004, Hunt Valley, Maryland 21031
www.nayax.com | (410) 666-3800 | info@nayax.com

AMIT 3.0

The unattended industry's
remote secure terminal

A complete M2M telemetry solution

Ideally suited for vending and
other unattended applications.

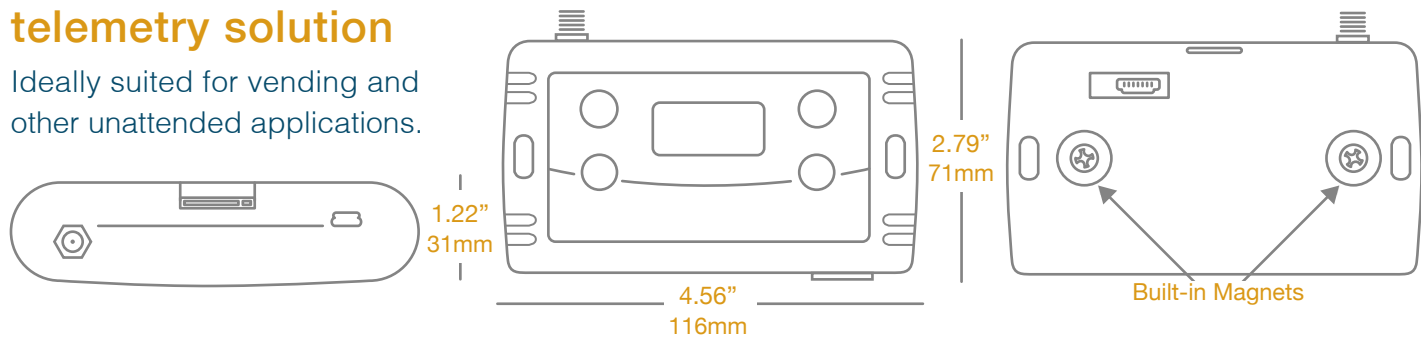

Temperature

Operating Temperature	-30°C - 50°C	-22°F - 122°F
Humidity	5% - 95% (non-condensing)	
Storage Temperature	-40°C - 60°C	-40°F - 140°F
Humidity	5% - 95% (non-condensing)	

Peripheral Ports

Mini USB (Host/Device), Ethernet with external Wi-Fi capability

1 X Reader interface

2 X RS232 interface (RS232 or TTL level manageable through software)

2 X Pulse input/output interfaces + pulse input (Inhibit)

2 X Sensors - door open, temperature sensor

Main Features

ARM Technology - Cortex , 32-bit, 168 Megahertz

High Security Encryption System: AES/DES/RSA/SSL

External flash up to 16 MB

MDB Spy - Capture and analyze messages from
all MDB peripherals

Physical Dimensions

H	4.56"	116mm
D	1.18"	30mm
W	2.55"	65mm
Weight	4.93 ounces	140 grams

Installation & Support

Easy installation - Device attached to the machine by
2 built in magnets

Remote software update

Multi-language Support - LCD text & Voice Audio

Menu navigation and service functionalities

Power

Power supply: input 10 - 42 Volt AC, 10 - 30 Volt DC,
External output 8 Volt DC

Power consumption 0.3 watt
(Idle State) - 1 watt (online) 1.9" / 48.3mm

2 X Super capacitors - for power down alert

Electrostatic discharge: IEC 61000-4-2, level 4 (ESD)

International Protection Rating: IP50

Using Nayax, automated machine operations all over the world are able to accept all forms of payment, with easy installation, clearance, monitoring and management.

Get Nayax for greater revenue,
reduced expenses and higher profits.
Contact us today to learn more.

Executive Plaza 1, 11350 McCormick Road, Suite 1004, Hunt Valley, Maryland 21031

www.nayax.com | (410) 666-3800 | info@nayax.com